

OPERATION MANUAL

# EDD-800

## DIGITAL TOTALIZER



Electronic Data Devices

Phone  
432-366-8699

Fax  
432-366-1106

P.O. Box 12128  
Odessa, Texas 79768  
USA

E-mail  
rkw@eddevices.com

Website  
www.eddevices.com



# Electronic Data Devices

Odessa, Texas USA  
432-366-8699  
rkw@eddevices.com

Electronic Data Devices

## EDD800 CALIBRATION INSTRUCTIONS

### Calibration for EDD800 Totalizer

Hold PROG/ENTER for 7 seconds

Setup 1 - Push Select

Setup 11 - Push PROG/ENTER  
Push SELECT until you reach the type of Measurement needed  
Push PROGRAM  
Push SELECT

Setup 12 - Push PROG/ENTER  
Push SELECT until you reach the Decimal Setting needed  
Push PROG/ENTER  
Push SELECT

Setup 13 - Push PROG/ENTER  
Push CLEAR until you reach the position to Enter Calibration Factor  
Enter factor  
Push PROG/ENTER  
Example: Factor on Meter Tag X 42 = Calibration Factor  
 $900 \times 42 = 37800$   
Push SELECT to reach Number  
Push PROG/ENTER  
Push SELECT  
Screen should read 0037800

Setup 14 - Push SELECT

Setup 2 - Push CLEAR

Setup 21 - Push PROG/ENTER  
Push SELECT until you reach the Measurement needed  
Push PROG/ENTER  
Push SELECT

Setup 22 - Push PROG/ENTER  
Push SELECT until you reach the Time Factor needed  
Push PROG/ENTER  
Push SELECT

Setup 23 - Push SELECT

Setup 24 - Push PROG/Enter  
Push CLEAR until you reach the position to enter the Calibration Factor  
Enter factor  
Push PROG/ENTER  
Example: Factor on Meter Tag X 42 = Calibration Factor  
 $900 \times 42 = 37800$   
Push SELECT to get the Number  
Push PROG/ENTER  
Screen should read 0037800

Hold PROG/ENTER for 7 seconds & Totalizer is ready

**SAFETY RULES AND PRECAUTIONARY MEASURES**

- The manufacturer accepts no responsibility whatsoever if the instructions and procedures as described in this manual are not followed.
- Modifications of the F012-P implemented without preceding written consent from the manufacturer, will result in the immediate termination of product liability and warranty period.
- The manufacturer accepts no responsibility whatsoever if the following safety rules and precautions are not observed.
- Installation, use, maintenance and de-mounting of this equipment must be carried out by authorized technicians.
- Check the mains voltage and information on the manufacturer's plate before installing the unit.
- Check all connections, settings and technical specifications of the various peripheral devices and the rate/totalizer F012-P.
- Open the casing only if all leads are potential free.
- Never touch the electronic components (ESD sensitivity).
- Never expose the system to heavier conditions than allowed according to the casing classification (see manufacture's plate and chapter 4.2.).
- If the operator detects errors or dangers, or disagrees with the safety precautions taken, then the owner or principal responsible should be informed immediately.
- The local labor and safety laws and regulations must be adhered to.

**CONTENTS:**

Safety rules and precautionary measures .....2  
Contents: .....2  
1. Introduction .....3  
1.1. About the operation manual .....3  
1.2. Control panel .....3  
1.3. Brief description of the rate/Totalizer F012-P .....3  
2. Operational .....4  
2.1. General .....4  
3. Configuration .....5  
3.1. Introduction .....5  
3.2. Programming SETUP-level .....5  
3.2.1. General .....5  
3.2.2. Prog-procedure .....7  
3.2.3. SETUP .....7  
3.2.3.1. Total - 1 .....7  
3.2.3.2. Flowrate - 2 .....8  
3.2.3.3. Display - 3 .....8  
3.2.3.4. Power management - 4 .....9  
3.2.3.5. Flowmeter - 5 .....9  
3.2.3.6. Others - 6 .....10  
4. Installation .....11  
4.1. General directions .....11  
4.2. Installation / surrounding conditions .....11  
4.3. Dimensions .....11  
4.4. Installing the hardware .....12  
4.4.1. Introduction .....12  
4.4.2. Voltage supply flowmeter pick-up .....12  
4.4.3. Terminal connectors .....13  
5. Intrinsic safety connections .....16  
6. Maintenance .....22  
6.1. General directions .....22  
Appendix A: Technical specification F012-P .....23  
Appendix B: Problem solving .....24  
Index: .....25  
Notes: .....26  
List of configuration settings F012-P .....28

## 1. INTRODUCTION

### 1.1. ABOUT THE OPERATION MANUAL

This operation manual is divided into two main sections;

The daily use of the unit is described in chapter 2 "Operation". This instruction is meant for users. The following chapters and appendices are exclusively meant for electricians/technicians. Extensive details of all software settings and information regarding installation of the hardware can be found here.

### 11 SETUP-REFERENCES

In the margin of this manual, SETUP-references have been included so that explanations regarding setup-level can easily be looked up, 11 in this case for example.

### 1.2. CONTROL PANEL

The following keys are available:



Fig. 1: Control Panel.

Functions of the keys:

- ◆ **PROG / ENTER:** This key has no function at operator level. It is used only to configure the unit; please read chapter 3.
- ◆ **SELECT / ▲:** This key is used to SELECT accumulated total. The arrow-key ▲ is only used to configure the unit; please read chapter 3.
- ◆ **CLEAR / ►:** Press this key twice to CLEAR the value for Total. The arrow-key ► is only used to configure the unit; please read chapter 3.

### 1.3. BRIEF DESCRIPTION OF THE RATE/TOTALIZER F012-P

The rate/totalizer F012-P is a microprocessor driven instrument designed to display flowrate, Total and accumulated Total. For that purpose, one flowmeter with pulse or coil output can be connected to the F012-P.

The F012-P was designed to be implemented in many types of applications. For that reason, a setup-level is available to configure your rate/totalizer according to your specific requirements. SETUP includes several important features, such as K-factors and measurement units.

As standard, the unit has to be powered with 8-30V DC. Optionally available is battery power. To extend the battery-life time, please make use of the power-management functions as described in chapter 3.2.3.3.

With the intrinsically safe option, Model F012-P-XI can be installed in a hazardous area according to EEx ia IIB/IIC T4. Please read chapter 5. for more information.



## 2. OPERATIONAL

### 2.1. GENERAL

This chapter describes the daily use of the rate/totalizer. This instruction is meant for users / operators.

In general, the rate/totalizer will always function at Operator level. The information displayed is dependant up on the SETUP-settings. All pulses generated by the connected flow meter are measured by the F012-P in the background, whichever screen refresh rate setting is chosen. After pressing a key, the display will be updated very quickly during a 30 second period, after which it will slow-down again.



Fig. 2: Example of display information during process.

For the Operator, the following functions are available:

- ◆ Display Rate/Total or Rate:  
This is the main display information of the F012-P. After selecting any other information, it will always return to this main display automatically. The flowrate is either displayed on the bottom line or with 17mm digits on the upper line. When "-----" is shown, then the flowrate value is too high to be displayed. The arrows ↕ indicate the increase/decrease of the flowrate trend.
- ◆ Clear Total:  
The value for Total can be re-initialized. To do so, press CLEAR twice. After pressing CLEAR once, the flashing text "PUSH CLEAR" is displayed. To avoid re-initialization in that stage, press a different key or wait for 20 seconds. Re-initialization of Total DOES NOT influence the accumulated Total.
- ◆ Display Accumulated Total:  
When the SELECT-key is pressed, Total and Accumulated Total are displayed. The Accumulated Total cannot be re-initialized. The value will count up to 99,999,999,999. The unit and number of decimals are displayed according to the configuration settings for Total.
- ◆ Low-battery alarm:  
When the battery voltage drops, it must be replaced. At first "low-battery" will flash, but as soon as it is displayed continuously, the battery MUST be replaced shortly after! Only official batteries may be used, or else the guarantee will be terminated. The remaining lifetime after the first moment of indication is generally several days up to some weeks.



Fig. 3: Example of low-battery alarm.

- ◆ Alarm 01-04:  
When "alarm" is displayed, please consult Appendix B: problem solving.

### 3. CONFIGURATION

#### 3.1. INTRODUCTION

This and the following chapters are exclusively meant for electricians and non-operators. Here, a detailed description of all software settings and hardware connections are provided.

- ◆ *Installation, use, maintenance and de-mounting of this equipment must be carried out by authorized technicians only.*
- ◆ *Take careful notice of the "Safety rules and precautionary measures" at the front of this manual.*

#### 3.2. PROGRAMMING SETUP-LEVEL

##### 3.2.1. GENERAL

Configuration of the F012-P is done at setup-level. Setup-level is reached by pressing the PROG/ENTER key for 7 seconds; at which time, both arrows ⇄ will be displayed. In order to return to the operator level, PROG will have to be pressed for three seconds. Alternatively, if no keys are pressed for 2 minutes, the unit will exit SETUP automatically.

SETUP can be reached at all times while the F012-P remains fully operational.

##### Password:

A password may be required to enter SETUP. Without this password access to SETUP is denied.

SETUP is divided into several main- and sub-functions. Main functions are selected with ▸ and sub-functions with ▲.

Each function has a unique number, which is displayed below the word "SETUP" at the bottom of the display. The number is a combination of two figures. The first figure indicates the main-function and the second figure the sub-function: 12 is the second sub-function of main-function 1. Additionally, each function is expressed with a keyword.

After selecting a sub-function, the next main function is selected after scrolling through all "active" sub-functions (e.g. 1▲, 11▲, 12▲, 13▲, 14▲, 1▸, 2▸, 3▸, 31 etc.).

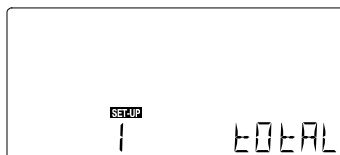
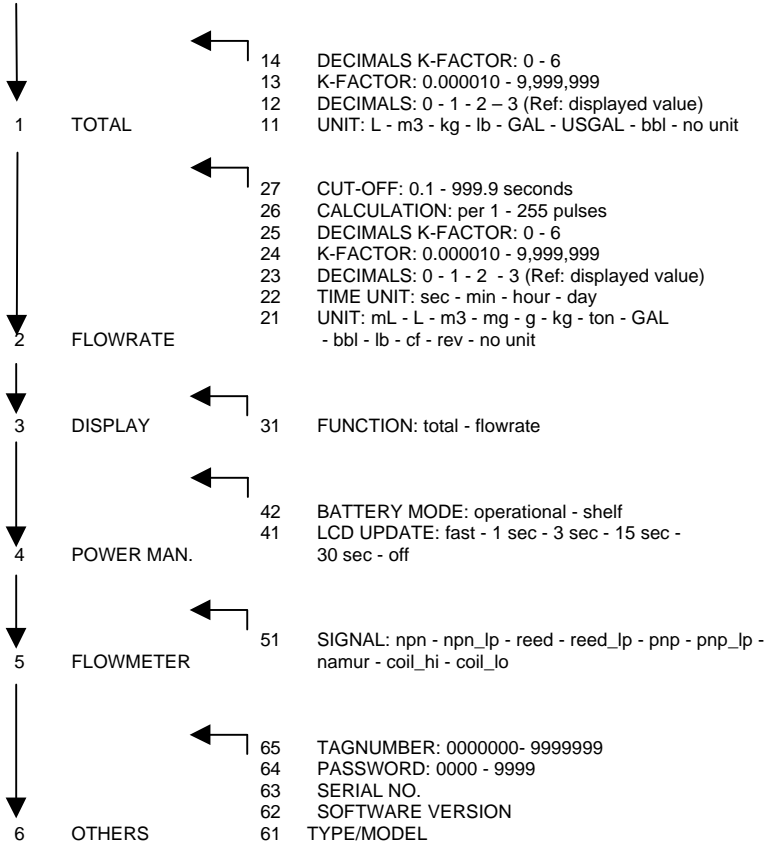

Fig. 4: Example of main-function 1.



Fig. 5: Example of sub-function 11: unit for Total.

SETUP has been divided as follows:



### 3.2.2. PROG-PROCEDURE

The PROG-procedure is applicable for programming, selecting or deleting values in setup-level. The procedure is executed as follows:

- 1) press PROG briefly,
- 2) enter a value or make a selection with the  $\blacktriangleright$   $\blacktriangleleft$  keys.
- 3) confirm the operation by pressing ENTER.

After pressing PROG, the word PROGRAM will flash until the PROG-procedure is completed.

To change a value, use  $\blacktriangleright$  to select the digits and  $\blacktriangleleft$  to increase that value. To select a setting, both  $\blacktriangleleft$  and  $\blacktriangleright$  can be used. When the new value is not valid, the increase sign  $\blacktriangleleft$  or decrease-sign  $\blacktriangleright$  will be displayed while you are programming.

When data is altered but ENTER is not pressed, then the alteration can still be cancelled by waiting for 20 seconds or by pressing ENTER for three seconds: the PROG-procedure will be exited automatically and the former value reinstated.

Please note that alterations will only be set after ENTER has been pressed!

### 3.2.3. SETUP

#### 3.2.3.1. TOTAL - 1

##### 11 TOTAL; MEASUREMENT UNIT - 11:

SETUP - 11 determines the measurement unit for TOTAL and Accumulated Total. The following units can be selected:

L - m3 - kg - lb. - GAL - USGAL - bbl - \_ (no unit).

Alteration of the measurement unit will have consequences for operator and setup-level values. Please note that the K-factor has to be adapted as well. (The calculation is not done automatically)

##### 12 TOTAL; NUMBER OF DECIMALS DISPLAYED - 12:

This setting determines for Total and Accumulated Total the number of digits following the decimal point. The following can be selected:

0000 - 111.1 - 22.22 - 3.333

##### 13 TOTAL; K-FACTOR - 13:

The K-factor is used to calculate a volumetric quantity based on the number of pulses received within a specified time period. This K-factor is determined on the basis of the measurement unit and the number of pulses generated per measurement unit by the flowmeter.

Enter the number of pulses generated by the flowmeter per selected measurement unit (e.g. per liter). The more accurate the K-factor, the more accurate the functioning of the system will be..

Example 1:                    Calculating the K-factor.  
*Let us assume that the flowmeter generates 6.5231 pulses per gallon and the selected measurement unit is Gallons. So, the K-Factor is 6.5231. Enter for SETUP - 13: "6523100" and for SETUP - 14 decimals K-factor "6".*

Example 2:                    Calculating the K-factor.  
*Let us assume that the flowmeter generates 2.4813 pulses per liter and the selected unit is "cubic meters / m3". A cubic meter consists of 1000 parts of one liter which implies 2,481.3 pulses per m3. So, the K-factor is 2,481.3. Enter for SETUP - 13: "2481300" and for SETUP - 14 - decimals K-factor "3".*

##### 14 TOTAL; NUMBER OF DECIMALS FOR K-FACTOR TOTAL - 14:

This function determines the number of decimals for the K-factor (see 13). The following can be selected:

0 - 1 - 2 - 3 - 4 - 5 - 6

Please note that this function influences the accuracy of the K-factor indirectly. This setting has NO influence on the displayed number of digits for Total (SETUP 12)!



### 3.2.3.2. FLOWRATE - 2

The settings for Total and Flowrate are entirely separate. In this way, different units of measurement can be used for each e.g. cubic meters for Total and liters for flowrate.

#### 21 FLOWRATE; MEASUREMENT UNIT - 21:

SETUP - 21 determines the measurement unit for flowrate.  
The following units can be selected:

mL - L - m3 - mg - gr - kg - ton - GAL - bbl - lb. - cf - rnd (round for RPM) \_ (no unit).

Alteration of the measurement unit will have consequences for operator and setup-level values.  
Please note that the K-factor has to be adapted as well. (The calculation is not done automatically)

#### 22 FLOWRATE; TIME UNIT - 22:

The Flowrate can be calculated per second (SEC), minute (MIN), hour (HR) and day (DAY).

#### 23 FLOWRATE; NUMBER OF DECIMALS DISPLAYED- 23:

This setting determines for Flowrate the number of digits following the decimal point. The following can be selected:

00000 - 1111.1 - 2222.22 - 3333.333

#### 24 FLOWRATE; K-FACTOR - 24:

The K-factor is used to calculate a volumetric quantity based on the number of pulses received within a specified time period. This K-factor is determined on the basis of the measurement unit and the number of pulses generated per measurement unit by the flowmeter.

Enter the number of pulses generated by the flowmeter per selected measurement unit (e.g. per liter).  
The more accurate the K-factor, the more accurate the functioning of the system will be. For examples see SETUP 13.

#### 25 FLOWRATE; NUMBER OF DECIMALS FOR K-FACTOR - 25:

This setting determines the number of decimals for the K-factor (see 24).  
The following can be selected:

0 - 1 - 2 - 3 - 4 - 5 - 6

Please note that this SETUP - influences the accuracy of the K-factor indirectly.

This setting has NO influence on the displayed number of digits for "flowrate" (SETUP 23)!

#### 26 FLOWRATE; CALCULATION - 26:

The flowrate is calculated by measuring the time between pulses. As several types of flowmeters have an unequal pulse-train, it is advised to calculate the flowrate over several pulses, for example 10 pulses; the maximum value is 255 pulses. Please understand that the calculation time for very low frequencies (0.1-5Hz) is influenced by this setting as well; so do not program too many pulses!  
When the frequency is above 3kHz. during normal conditions, it is advised to calculate over 50 or more pulses.

#### 27 FLOWRATE; CUT-OFF TIME - 27:

With this setting, you determine a minimum flow requirement thresh-hold, if during this time less than XX-pulses (see setting 26) are generated, the flowrate will be displayed as zero. Time in seconds.

### 3.2.3.3. DISPLAY - 3

#### 31 DISPLAY; FUNCTION - 31

The large 17mm digits can be set to display Total or Flowrate. When Total is selected, both Total and Flowrate are displayed simultaneously. When Flowrate is selected, Total will be displayed after pressing select. .

### 3.2.3.4. POWER MANAGEMENT - 4

When used with the internal battery option, the user may hold the concern of reliable measurement over a long period of time. The F012-P has several smart power management functions to extend the battery life time significantly. Two of these functions can be set:

#### 41 POWER MANAGEMENT; LCD NEW - 41:

The calculation of the display-up-date time influences the power consumption significantly. When the application does not require a fast display update, we advise you to select a slow refresh-rate. Please understand that NO information will be lost; every pulse will still be counted and the output-signals are not influenced in any way.

The following can be selected:

Fast - 1 sec - 3 sec - 15 sec - 30 sec - off.

Example: battery life-time with a coil pick-up, 1KHz. pulses and FAST update: about 2 years.  
battery life-time with a coil pick-up, 1KHz. pulses and 1 sec update: about 7 years.

Please note that - after a button has been pressed by the operator - the display refresh-rate will be FAST during a 30 second period. When "OFF" is selected, the display will be switched-off after 30 seconds and will be switched-on as soon as a button has been pressed.

#### 42 POWER MANAGEMENT; BATTERY-MODE - 42:

The unit has two modes: operational or shelf. When shelf is selected, you can store the unit for several years; it will not count pulses, the display is switched off but all settings are stored. In this mode, power consumption is extremely low.

Normally, the unit will be operational.

### 3.2.3.5. FLOWMETER - 5

#### 51 FLOWMETER; SIGNAL - 51:

The F012-P is able to handle several types of signals. The type of flowmeter pickup / signal is selected in software with SETUP 51.

TYPE OF SIGNAL	EXPLANATION	RESISTANCE	POWER CONSUMPTION	FREQ. / mV	REMARK
<b>NPN</b>	Standard NPN input	100K pull-up	Relatively high	16 KHz.	(open collector)
<b>NPN - LP</b>	NPN with low pass filter	100K pull-up	Relatively high	2.2 KHz.	(open collector) less sensitive
<b>REED</b>	Reed-switch input	1M pull-up	low	2.2 KHz.	
<b>REED - LP</b>	Reed-switch + low pass filter	1M pull-up	low	225 Hz.	Less sensitive
<b>PNP</b>	Standard PNP input	100K pull-down	Relatively high	6.3 KHz.	
<b>PNP - LP</b>	PNP input with low pass filter	100K pull-down	Relatively high	700 Hz.	Less sensitive
<b>NAMUR</b>	Standard namur input	1K pull-down	High	12 KHz.	External power required
<b>COIL HI</b>	High sensitive coil input	-	Very low	25mV p.t.p.	Sensitive to disturbance!
<b>COIL LO</b>	Low sensitive coil input	-	Very low	90mV p.t.p.	Normal sensitivity

**3.2.3.6. OTHERS - 6**

**61 OTHERS; TYPE OF MODEL - 61:**

For support and maintenance it is important to have information about the characteristics of the rate/totalizer. Your supplier will ask for this information in the case of a serious breakdown or to assess the suitability of your model for upgrade considerations.

**62 OTHERS; VERSION SOFTWARE - 62:**

For support and maintenance it is important to have information about the characteristics of the rate/totalizer. Your supplier will ask for this information in the case of a serious breakdown or to assess the suitability of your model for upgrade considerations.

**63 OTHERS; SERIAL NUMBER - 63:**

For support and maintenance it is important to have information about the characteristics of the rate/totalizer. Your supplier will ask for this information in the case of a serious breakdown or to assess the suitability of your model for upgrade considerations.

**64 OTHERS; PASSWORD - 64:**

All SETUP-values can be password protected. This protection is disabled with value 0000 (zero). Up to and including 4 digits can be programmed, e.g. 1234.

**65 OTHERS; TAGNUMBER - 65:**

For identification of the unit and communication purposes, a unique tagnumber of maximum 7 digits can be entered.

4. INSTALLATION

4.1. GENERAL DIRECTIONS

- ◆ Installation, use, maintenance and de-mounting of this equipment must be carried out by authorized technicians only.
- ◆ Take good notice of the "Safety rules and precautionary measures" in the front of this manual.
- ◆ For Intrinsically Safe applications: read chapter 5.

4.2. INSTALLATION / SURROUNDING CONDITIONS

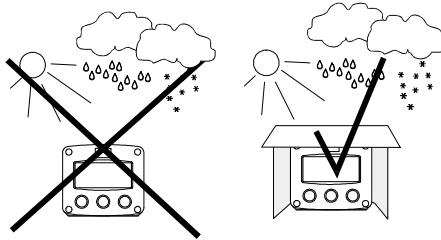

Take the valid IP classification of the casing into account (see manufactures plate). NEVER expose even the IP65 casing to strongly varying (weather) conditions. When panel-mounted, the unit is IP65! When used in very cold surroundings or heavy varying temperatures, take the necessary precautions against moisture by placing a dry sachet of silica gel e.g. before closing in the casing.

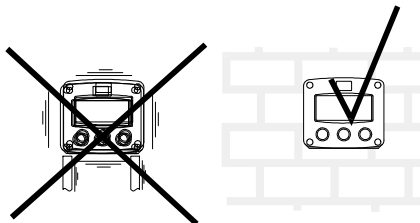

Do mount the rate/totalizer on solid ground surface to avoid vibrations.

4.3. DIMENSIONS

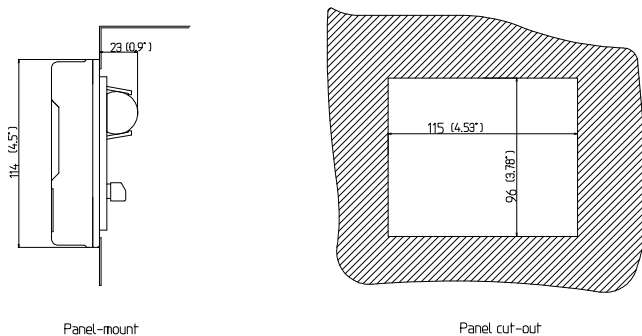

Fig. 6: Dimensions ABS panel mount casing / panel cut-out (IP65).

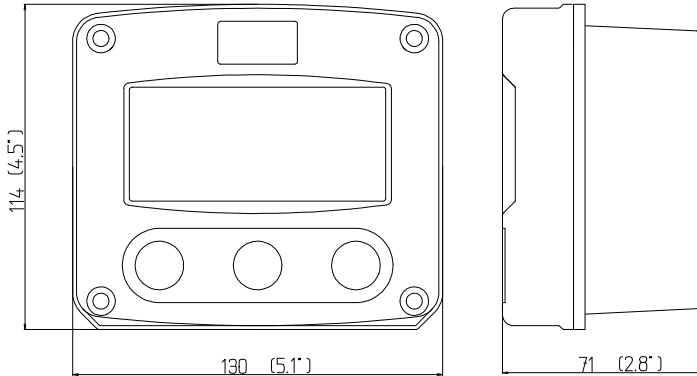

Fig. 7: Dimensions ABS wall-mount casing.

#### 4.4. INSTALLING THE HARDWARE

##### 4.4.1. INTRODUCTION

- ◆ *This unit must be installed in accordance with the EMC guidelines (Electro Magnetic Compatibility).*
- ◆ *Electro static discharge does inflict irreparable damage to electronics! The electrician has to discharge himself by touching a well-grounded object before opening the casing.*
- ◆ *For Intrinsically Safe applications: read chapter 5.*

##### FOR INSTALLATION, PAY EMPHATIC ATTENTION TO:

- ◆ Separate cable glands with effective IP67 seals for all wires.
- ◆ Unused cable entries: do fit IP67 plugs.
- ◆ A reliable earth for components, electronics and if be applicable, the metal casing.
- ◆ An effective screened cable for signal wiring and grounding of the screening in terminal 3 (GND).

##### 4.4.2. VOLTAGE SUPPLY FLOWMETER PICK-UP

For Intrinsically Safe applications: read chapter 5.

##### Externally powered applications 8-30 V DC:

When the F012-P is externally powered, the sensor can be powered with the same voltage by using the shared terminal (4). If the unit is fitted with a battery as well, the output voltage of 3.2V DC from the battery is blocked automatically as soon as you connect the external power-supply.

##### Battery powered applications:

A supply voltage of 3.2 Volt DC is available for the signal output of the flowmeter. **This voltage MAY NOT be used to power the flowmeters electronics, converters etc.** as it is not a power supply as such! All energy used by the flowmeters pick-up influences the battery life directly; it is strongly advised to use a "zero power" pickup with the battery option, such as a coil or reed-switch. It is possible to use a low power input NPN or PNP output signal, but the battery life time will be reduced.

**NAMUR**

For a NAMUR pick-up, an external power supply of 8.2-24VAC/DC is required. The voltage supply to the flowmeter should be according to DIN19 234 (8.2VDC) when NAMUR-input is selected. Please note that the optional power-module is available, incorporating a variable DC sensor supply.

**4.4.3. TERMINAL CONNECTORS**

For *Intrinsically Safe* applications: read chapter 5.

The following terminal connectors are available:

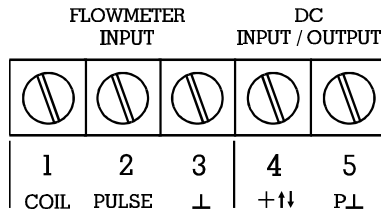

Fig.: 8 Overview terminal connectors.

**REMARKS TERMINAL CONNECTORS:****Terminal 1-3; Flowmeter input**

Two basic types of flowmeter signal can be connected to the F012-P: pulse (terminal 2) or coil (terminal 1). The screen of the signal wire must be connected to terminal 03 (GND). The voltage supply (3.2VDC) to the flowmeter should be connected to terminal 4. Please read par. 4.4.2. for power supply flowmeter. The maximum input frequency is approximately 10 KHz (depending on the type of signal) **For Intrinsically safe applications: please read chapter 5.**

**Coil-signal:**

The F012-P is suitable for flowmeters which have a coil output. The sensitivity of the input can be selected with SETUP - 51. Two selections can be made: COIL LO: sensitivity from about 120mV peak to peak (p.t.p.) or COIL HI: sensitivity from about 20mV peak to peak.

**For Intrinsically safe applications: please read chapter 5.**

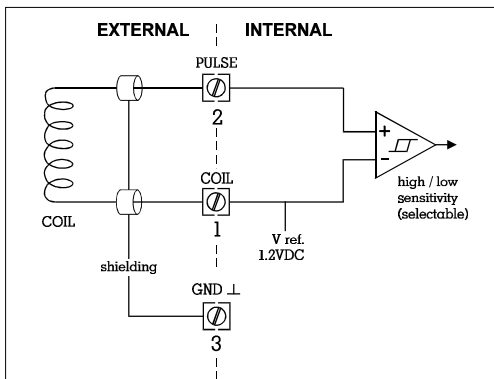

**Pulse-signal NPN/PNP:**

The F012-P is ideally suitable for flowmeters which have a pulse output that is equal or almost equal to the supply voltage (3.2VDC). For reliable detection, the pulse amplitude has to cross 1.2VDC once per cycle. Transducers which generate a higher amplitude than 3.2VDC can still be used, but the detection level is still 1.2VDC. The Maximum voltage input is rated for pulse amplitudes of 24VDC.

**For Intrinsically safe applications: please read chapter 5.**

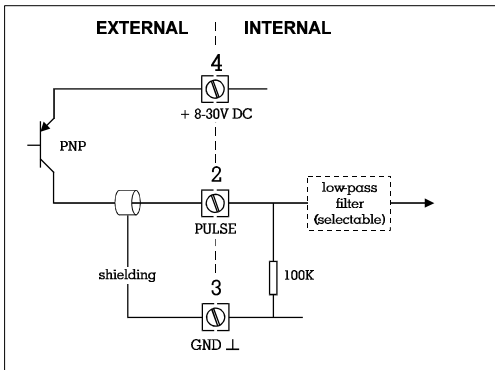
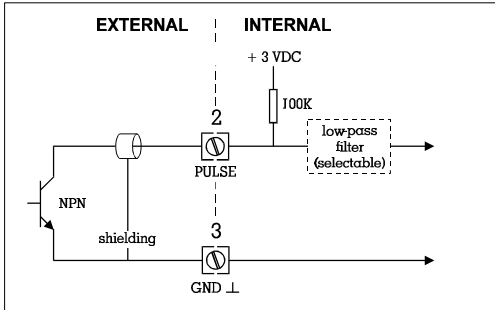

**Reed-switch:**

The F012-P is suitable for flowmeters which have a reed-switch. To avoid pulse bounce from the reed-switch, it is advised to select REED LP - low-pass filter (setting 51).

**For Intrinsically safe applications: please read chapter 5.**

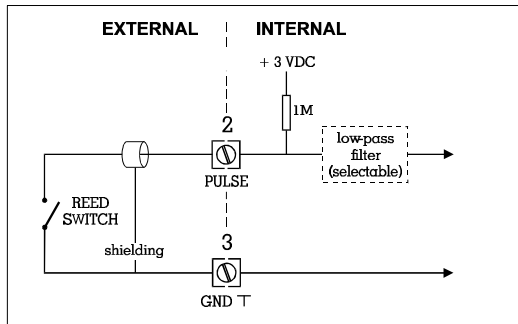
**NAMUR-signal:**

The signal input is according DIN19 234. Please notice that an external power supply is required. Maximum voltage input is 10VDC for NAMUR-type input.

**For Intrinsically safe applications: please read chapter 5.**

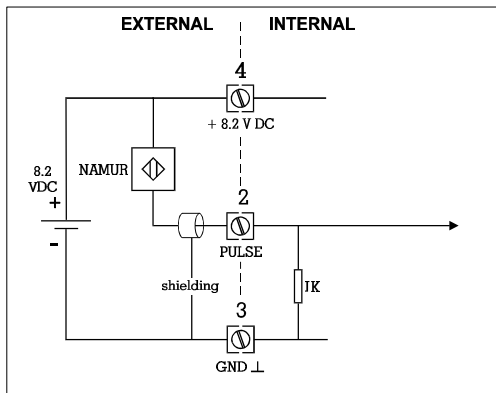
**Terminal 4 and 5; external power supply 8-30V DC:**

Connect an external power-supply of maximum 30V DC to these terminals. Connect the "-" to terminal 5 and the "+" to terminal 4. The output voltage from the battery (option) is blocked automatically as soon as a higher input voltage than 3.2 V DC is connected: it won't damage the battery.



**5. INTRINSIC SAFETY CONNECTIONS**

The F012-P can be installed in a hazardous area when option XI for intrinsically safe has been supplied. In most applications, the classification for the F012-P-XI is EEx ia IIB T4 where a maximum of two barriers can be connected to the unit. However, the F012-P-XI can be used in gas group C applications according to EEx ia IIC T4 when no external barriers are connected to the unit. Please study the following pages with wiring diagrams per signal type for coil, NPN, PNP, reed-switch and Namur sensors.

**When installing the F012-P-XI in hazardous areas, the wiring and installation must comply with appropriate installation standards.**

**COIL INPUT CIRCUIT: TERMINALS 1 (COIL), 2 (SIGNAL) AND 3 (GND):**

For explosion protection classification: intrinsic safety EEx ia IIB T4, only for connection to a certified intrinsically safe circuit, with following maximum values:

- U<sub>i</sub> = 30V DC
- I<sub>i</sub> = 100mA
- P<sub>i</sub> = 0.75W

the effective internal capacitance and inductance are negligibly small.

**COIL INPUT CIRCUIT: TERMINALS 1 (COIL), 2 (SIGNAL) AND 3 (GND):**

For explosion protection classification: intrinsic safety EEx ia IIC T4 or EEx ia IIB T4, only for connection to a certified intrinsically safe circuit, with following maximum values:

- U<sub>o</sub> = 5.1V
- I<sub>o</sub> = 5.2mA
- P<sub>o</sub> = 27mW

maximum allowed external capacitance Co and maximum allowed external inductance Lo depending on gas group, in accordance with following table:

	IIB	IIC
Lo <=	1H	1H
Co <=	1000uF	88uF

**NAMUR INPUT CIRCUIT: TERMINALS 2 (SIGNAL) AND 3 (GND):**

For explosion protection classification: intrinsic safety EEx ia IIB T4, only for connection to a certified intrinsically safe circuit, with following maximum values:

- U<sub>i</sub> = 30V DC
- I<sub>i</sub> = 100mA
- P<sub>i</sub> = 0.75W

the effective internal capacitance and inductance are negligibly small.

**PNP INPUT CIRCUIT: TERMINALS 2 (SIGNAL) AND 3 (GND):**

For explosion protection classification: intrinsic safety EEx ia IIB T4, only for connection to a certified intrinsically safe circuit, with following maximum values:

- U<sub>i</sub> = 30V DC
- I<sub>i</sub> = 100mA
- P<sub>i</sub> = 0.75W

the effective internal capacitance and inductance are negligibly small.

**PNP INPUT CIRCUIT: TERMINALS 2 (SIGNAL) AND 4 (SUPPLY):**

For explosion protection classification: intrinsic safety EEx ia IIC T4 or EEx ia IIB T4, only for connection to a certified intrinsically safe circuit, with following maximum values:

- U<sub>o</sub> = 5.1V
- I<sub>o</sub> = 5.2mA
- P<sub>o</sub> = 27mW

maximum allowed external capacitance Co and maximum allowed external inductance Lo depending on gas group, in accordance with following table:

	IIB	IIC
Lo <=	1H	1H
Co <=	1000uF	88uF



**NPN OR REED-SWITCH INPUT CIRCUIT: TERMINALS 2 (SIGNAL) AND 3 (GND):**

For explosion protection classification: intrinsic safety EEx ia IIB T4, only for connection to a certified intrinsically safe circuit, with following maximum values:

$$U_i = 30V \text{ DC}$$

$$I_i = 100\text{mA}$$

$$P_i = 0.75W$$

the effective internal capacitance and inductance are negligibly small.

**NPN OR REED-SWITCH INPUT CIRCUIT: TERMINALS 2 (SIGNAL) AND 3 (GND): :**

For explosion protection classification: intrinsic safety EEx ia IIC T4 or EEx ia IIB T4, only for connection to a certified intrinsically safe circuit, with following maximum values:

$$U_o = 5.1V$$

$$I_o = 5.2\text{mA}$$

$$P_o = 27\text{mW}$$

maximum allowed external capacitance  $C_o$  and maximum allowed external inductance  $L_o$  depending on gas group, in accordance with following table:

	IIB	IIC
$L_o \leq$	1H	1H
$C_o \leq$	1000uF	88uF

**EXTERNAL POWER SUPPLY: TERMINALS 4 (SUPPLY), 3 (GND):**

For explosion protection classification: intrinsic safety EEx ia IIB T4, only for connection to a certified intrinsically safe circuit, with following maximum values:

$$U_i = 30V \text{ DC}$$

$$I_i = 100\text{mA}$$

$$P_i = 0.75W$$

the effective internal capacitance and inductance are negligibly small.

**BATTERY POWERED UNITS:**

In accordance with the certificate, only the I.S. certified battery type FW-LiBAT-001 should be used in case of replacement.

**CERTIFICATE F012-P-XI:**

Certificate of conformity for the F012-P-XI: **Ex-KEMA No. Ex-00.E.1109 X**



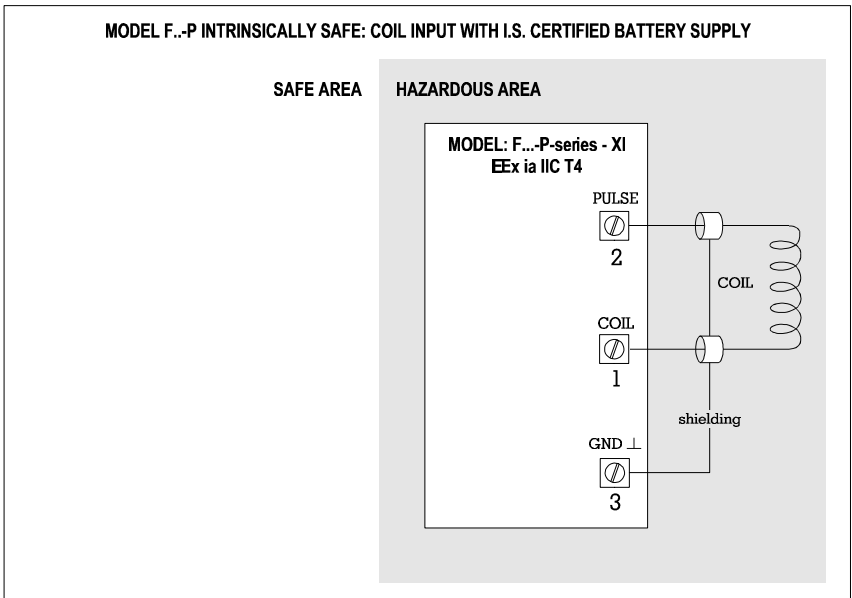
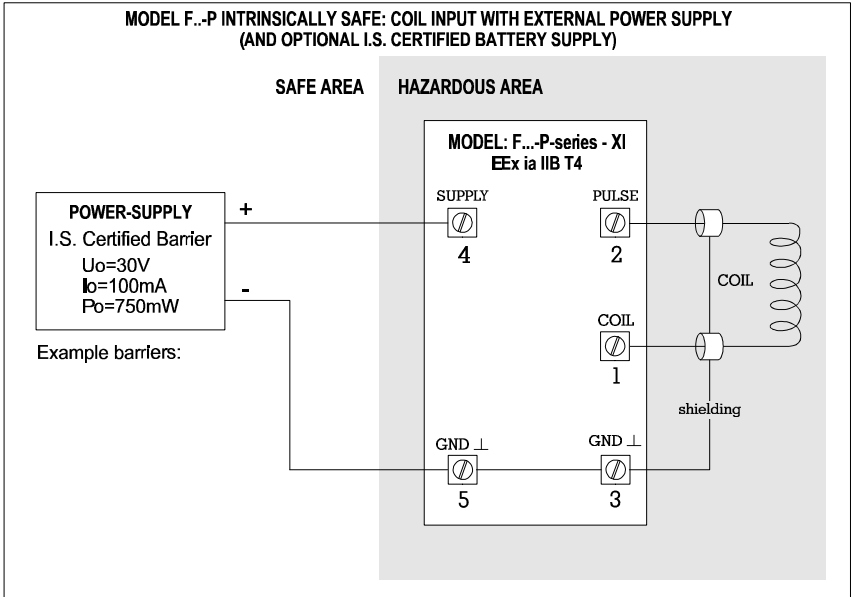

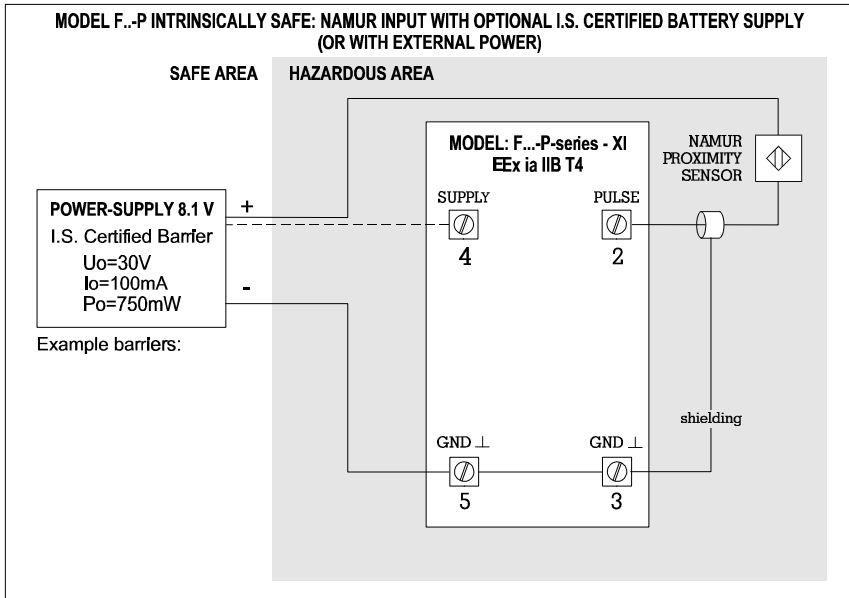
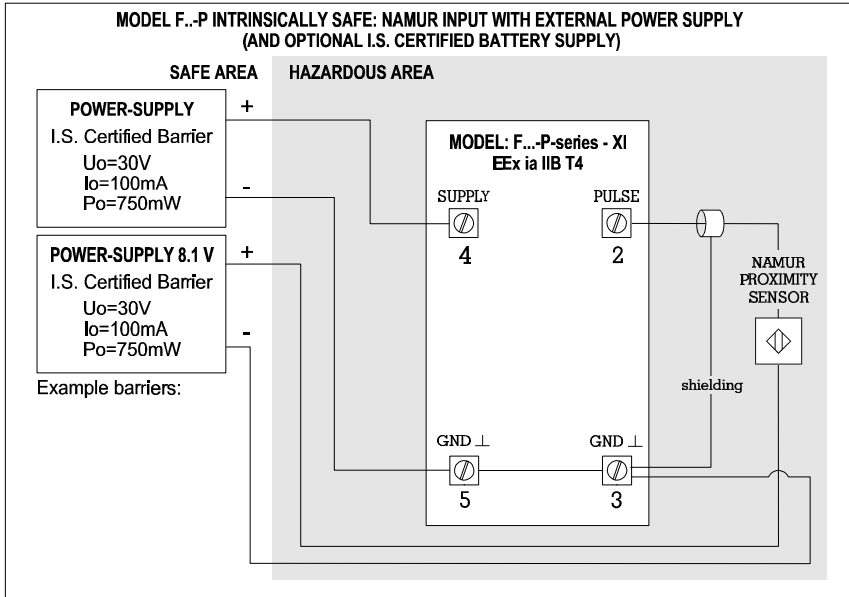

**MODEL F...P INTRINSICALLY SAFE: NPN / REED-SWITCH INPUT WITH EXTERNAL POWER SUPPLY  
(AND OPTIONAL I.S. CERTIFIED BATTERY SUPPLY)**

SAFE AREA      HAZARDOUS AREA

**POWER-SUPPLY**  
I.S. Certified Barrier  
 $U_o=30V$   
 $I_o=100mA$   
 $P_o=750mW$

Example barriers:

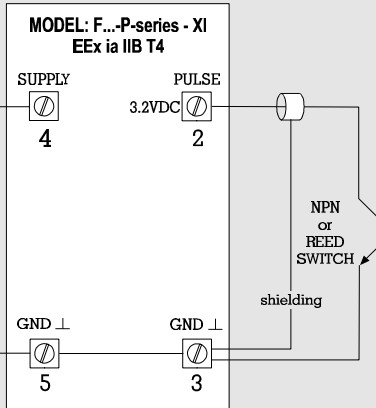

**MODEL F...P INTRINSICALLY SAFE: NPN / REED-SWITCH INPUT WITH OPTIONAL  
I.S. CERTIFIED BATTERY SUPPLY**

SAFE AREA      HAZARDOUS AREA

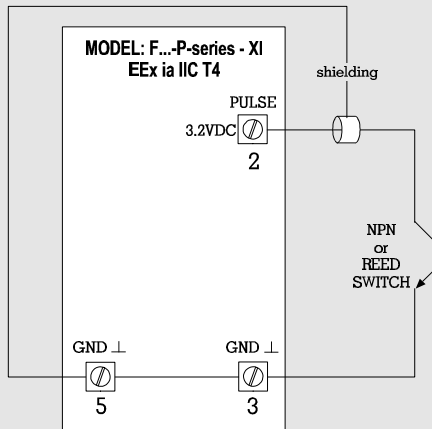

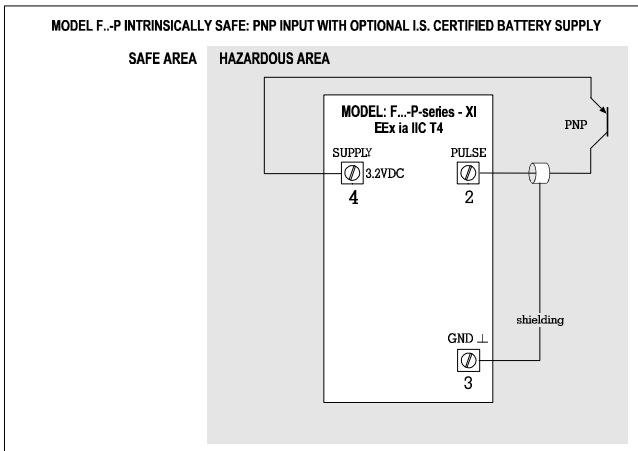
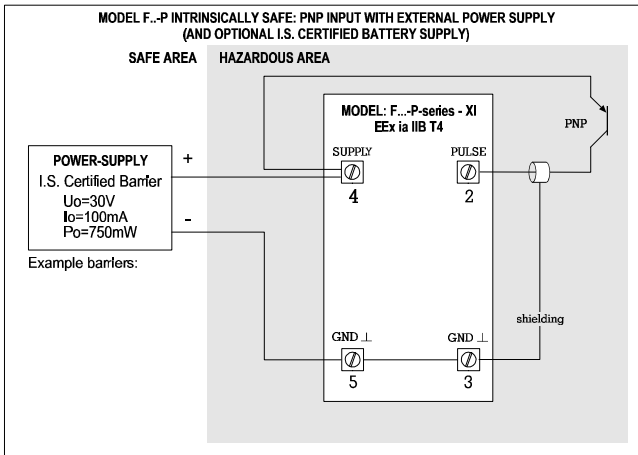
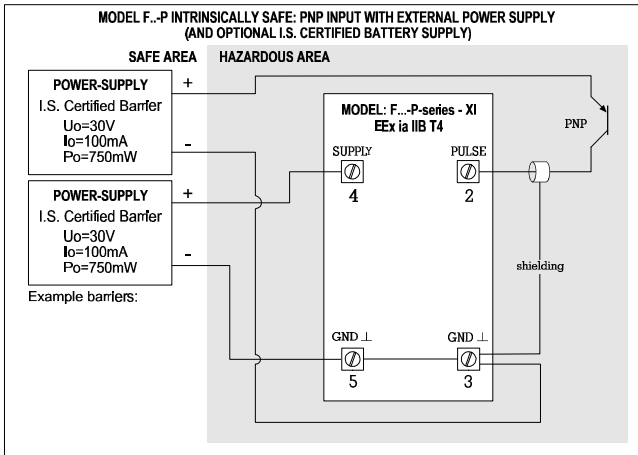

## 6. MAINTENANCE

### 6.1. GENERAL DIRECTIONS

- ◆ *Installation, use, maintenance and de-mounting of this equipment must be carried out by authorized technicians only.*
- ◆ *Take careful notice of the "Safety rules and precautionary measures" in the front of this manual.*

The rate/totalizer does not require special maintenance unless it is used in low-temperature applications and/or surroundings with high humidity (above 90% annual mean average). It is the customers responsibility to take all precautions to dehumidify the internal atmosphere of the F012-P in such a way that no condensation will occur, for example by placing dry silica-gel in the casing just before closing it. Furthermore, is required to replace or dry the silica gel from time to time as advised by the silica gel supplier.

#### **Battery life-time:**

It is influenced by several issues such as:

- Display update: see setting 41.
- low temperatures; the available power will be less due to battery chemistry.

It is advised to disable unused functions.

#### **Check periodically:**

- ◆ The condition of the casing, cable glands and front panel.
- ◆ The input/output wiring for reliability and aging symptoms.
- ◆ The process accuracy. As a result of wear and tear, re-calibration of the flowmeter might be necessary. Do re-enter any subsequent K-factor alterations.
- ◆ The indication for low-battery.
- ◆ Clean the casing with soapy-water; don't use any aggressive solvents as these might damage the polyester coating.

**APPENDIX A: TECHNICAL SPECIFICATION F012-P****GENERAL**

Display:	High intensity reflective alphanumeric LCD, UV-resistant.
Digits:	Seven 17mm (0.67") and eleven 8mm (0.31"). Various symbols and measuring units.
Refresh rate:	Selectable via menu: 8 times/sec - 30 sec's.
Case:	ABS - IP65 / NEMA 4. (Options below)
Mounting:	Standard panel-mount case. (Options below)
Dimensions:	130 x 114 x 50mm (5.1" x 4.5" x 1.97") - LxHxD.
Panel cut-out:	115 x 96mm (4.53" x 3.78") LxH.
Window:	Polycarbonate window.
Sealing:	EPDM and PE.
Control keys	Three industrial micro-switch keys. UV-resistant polyester keypad.
<b>Option HD:</b>	ABS IP65 / NEMA 4 wall-mount case. Dimensions: 130 x 114 x 71mm (5.1" x 4.5" x 2.8") - LxHxD.
<b>Option HA:</b>	Aluminium IP67 / NEMA 4 wall-mount, sensor head-mount case. Dimensions: 130 x 114 x 58mm (5.1" x 4.5" x 2.3") - LxHxD.
Operating temperature:	-30°C to +80°C (-22°F to +178°F).
Power requirements:	8-30V DC supply can be connected to power the unit.
<b>Option PA:</b>	Internal Lithium battery 3.2V DC: average lifetime seven years dependent upon settings and sensor type.
Sensor excitation:	same voltage as offered to power the unit.
Terminal connections:	Removable plug strip. Wire max. 1.5mm <sup>2</sup> .
Data protection:	EEPROM backup of all setting. Backup total and accumulated total every minute.
Hazardous area:	(optional) Cenelec approval ref: EEx ia IIB/IIC T4. CSA certification is pending. Maximum ambient 70°C (158°F). Option XI.
Environment CE:	EMC compliant ref: EN50081 and EN50082.
Pulse inputs:	Type P: Coil/sine wave (minimum 20mVpp or 80mVpp - sensitivity selectable), NPN/PNP, open collector, reed-switch, Namur.
Frequency:	Minimum 0 Hz - maximum 10 KHz for total and flowrate. Max frequency depends on signal type and internal low-pass filter. Reed switch with low-pass filter = max. 200 Hz.
Low-pass filter:	Available for all pulse signals.
Selection main function:	Total or Flowrate will be displayed with 17mm digits.

**OPERATOR FUNCTIONS**

General:	The Operator has three functions available: - TOTAL and Flowrate are displayed. - TOTAL can be reset by pressing CLEAR-key twice. - After pressing SELECT, Accumulated TOTAL will be displayed.
TOTAL:	17mm character-size - 7 digits. Measuring units: L, m3, GAL, USGAL, KG, lb, bbl, no unit. K-factor: 7 positions 0.000010 - 9,999,999. Number of decimals: max. three. TOTAL is resettable.
Accumulated Total:	8mm character-size - 11 digits. Acc. Total is not resettable. Uses the same K-factor, unit and decimals as TOTAL.
FLOWRATE:	8mm character-size or 17mm character-size - 5 digits. Settings independent of TOTAL. Measuring units: mL, L, m3, Gallons, KG, ton, lb, bl, cf, rnd, no unit. Time units: second, minute, hour, day. K-factor: 7 positions 0.000010 - 9,999,999. Number of decimals: max. three.



## APPENDIX B: PROBLEM SOLVING

In this appendix, several problems are included that can occur when the rate/totalizer is going to be installed or while it is in operation.

### Flowmeter does not generate pulses:

Check:

- Flowmeter, wiring and connection of terminal connectors (par. 4.4.4.),

### Flowmeter generates "too many pulses":

Check:

- Settings for Total and Flowrate: SETUP 11-14 and 21-27,
- Proper grounding of the F012-P - par. 4.4.4.
- Use screened wire for flowmeter signals and connect screen to terminal 3.

### Flowrate displays "0 / zero" while there is flow (total is counting):

Check:

- SETUP 22 / 25: are the K-factor and time unit correct?
- SETUP 26 / 27: The unit has to count the number of pulses according to setup 26 within the time according to setup 27. Make sure that 27 is set to eg.10.0 seconds. The result is that the unit has at least 10 seconds time to measure the number of pulses according to setup 26.

### The password is unknown:

If the password is not 1234, there is only one possibility left: call your supplier.

## ALARM

When the alarm flag starts to blink an internal alarm condition has occurred. Press the "select button" several times to display the 5-digit error code. The codes are:

- 0001: irrecoverable display-data error: data on the display might be corrupted.
- 0002: irrecoverable data-storage error: the programming cycle might have gone wrong: check programmed values.
- 0003: error 1 and error 2 occurred simultaneously

The alarm condition will almost certainly be handled internally and if all mentioned values still appear correct, no intervention by the operator is needed. If the alarm occurs more often or stays active for a longer time, please contact your supplier.

## INDEX:

accumulated Total	4	maintenance	22
actual settings	28	model	10
Battery powered	12; 17	NAMUR signal	13; 15; 16
<b>CLEAR</b>	3	Notes	26
Clear Total	4	operational mode	9
Coil-signal	13; 16	Operator level	4
Configuration	5	password	10; 24
Dimensions	11	Power management	9
display update	9	Problem solving	24
external power supply	15	<b>PROG / ENTER</b>	3
flowmeter		PROG-procedure	7
signal	9	Pulse-signal NPN/PNP	14; 16; 17
Flowmeter input	13; 16	rate/Total	4
flowrate		Reed-switch:	15; 17
calculation	8	<b>SELECT</b>	3
cut-off time	8	serial number	10
decimals	8	SETUP-level	5
decimals k-factor	8	shelf-mode	9
display 17mm digits	8	subfunction	5
k-factor	8	tagnumber	10
measuring unit	8	Technical specification	23
time unit	8	terminal connectors	13
Installation	11	total	
<b>Intrinsic safety</b>	16	decimals	7
IP classification	11	decimals k-factor	7
keys	3	k-factor	7; 8
low-battery	4	measuring unit	7
Low-battery alarm	4	version software	10
main-function	5		





## LIST OF CONFIGURATION SETTINGS F012-P

SETTING:	DEFAULT	DATE:	DATE:
----------	---------	-------	-------

**1 - TOTAL:**

11 unit	L		
12 decimals	0000000		
13 K-factor	0000001		
14 decimals K-factor	0		

**2 - FLOWRATE:**

21 unit	L		
22 time unit	/min		
23 decimals	0000000		
24 K-factor	0000001		
25 decimals K-factor	0		
26 calculation / pulses	10		
27 cut-off time	30.0 sec.		

**3 - DISPLAY**

31 function	total		
-------------	-------	--	--

**4 - POWER MAN.**

41 LCD-new	1 sec.		
42 mode	operational		

**5 - FLOWMETER**

51 signal type	coil-lo		
----------------	---------	--	--

**6 - OTHERS**

64 password	0000		
65 tagnumber	0000000		